

| REVISIONS | | | | |
|-----------|-----|-------------|---------|----------|
| ZONE | LTR | DESCRIPTION | DATE | APPROVED |
| | | RELEASED | 12-5-05 | |

DWG NO. 380-010150-001

- NOTES**
- 1 - ALL RADII .125
 - 2 - TEXT FONT MOORPARK
 - 3 - ENGRAVE TEXT "RF OUTPUT" .080 HIGH X .015 DP. CENTERED WITH HOLES AS SHOWN.

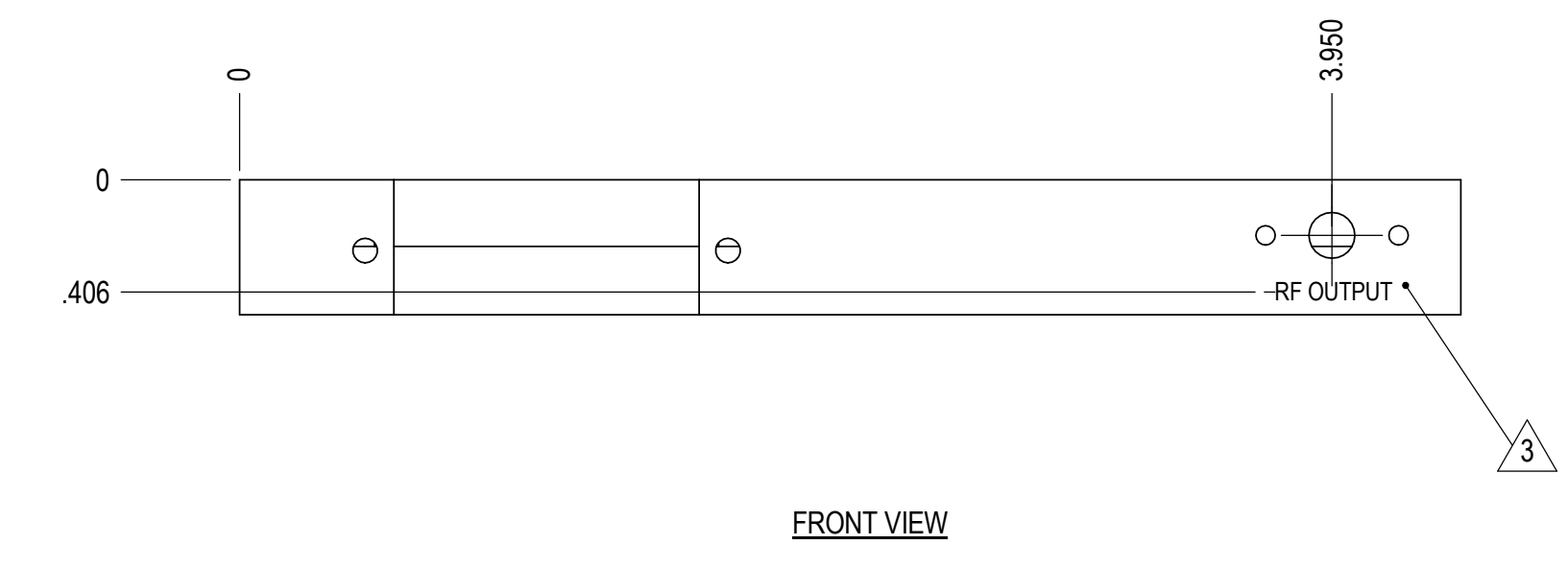
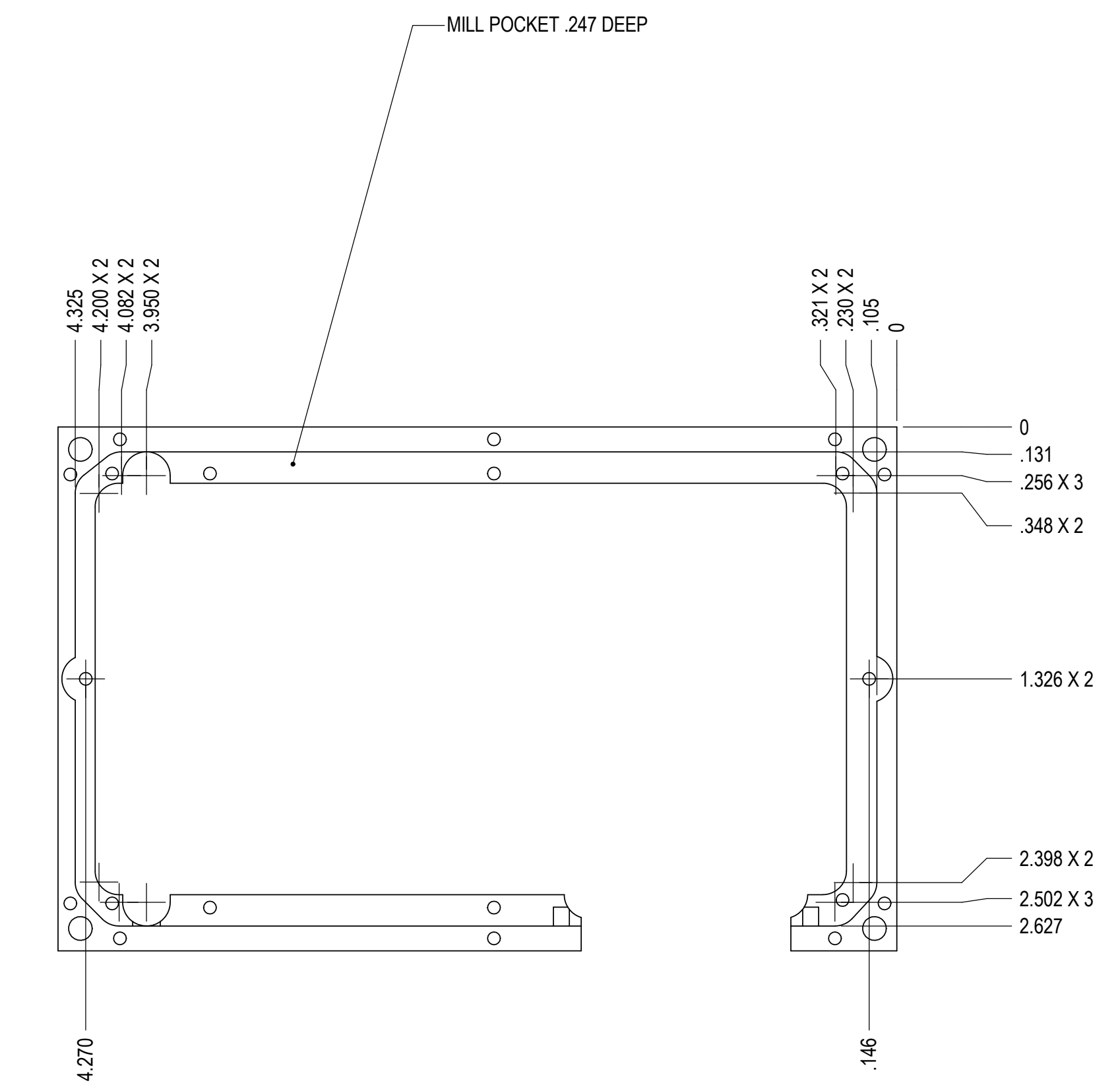
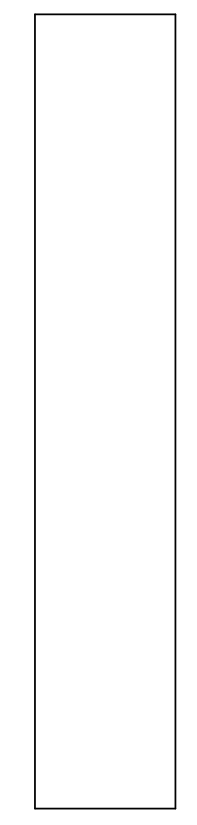
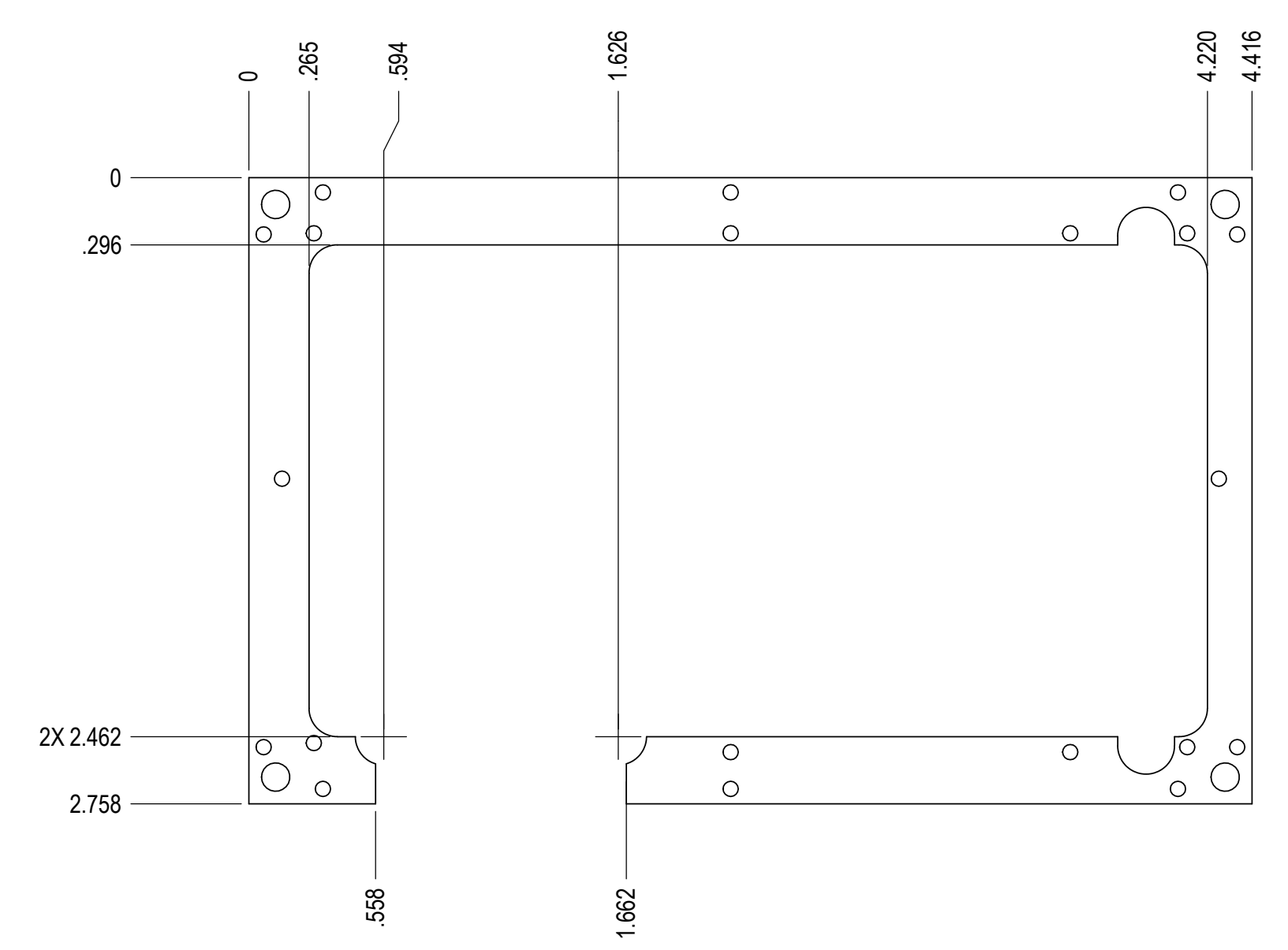
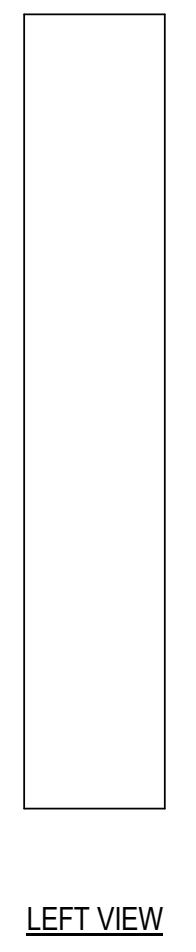
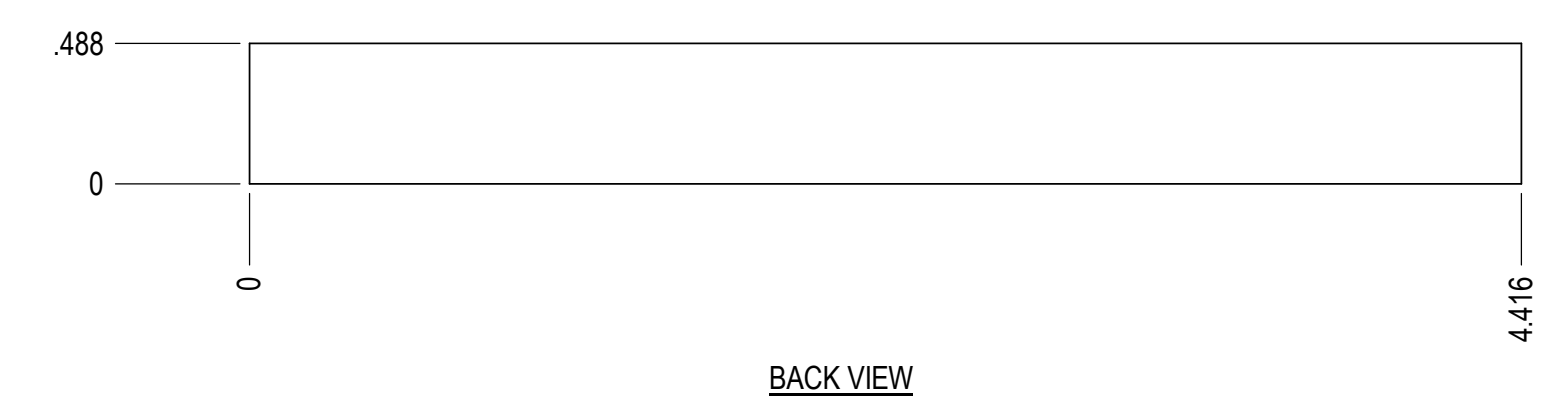

| | | |
|------------------------------------|--------------------------------|--|
| MATERIAL: AL 6061-T6 | CONTRACT NO. CONTRACTOR: | 120 South Third Street Fisher, IL 61943 (217) 897-1744 |
| FINISH: TUMBLE GOLD CHROMATE | DRAWN BY CHECKED BY Q.C. | ENGINEER PRODUCTION MECHANICAL |
| NEXT ASSY | USED ON | DESIGN ACTIVITIES APPROVAL |
| APPLICATION | SCALE 1:1 | DWG NO. 380-010150-001 REV - |

PRAXSYM, INC.
CHASSIS, SYNTHESIZER

SHEET 1 OF 2

HOLE LEGEND

- A - TAP 0-80 X .125 DP, 20 PLS
- B - DRILL .125 DIA THRU, 4 PLS
- C - TAP 2-56 THRU, 2 PLS
- D - TAP 4-40 THRU, 2 PLS
- F - DRILL .166 DIA THRU, 1 PLS
- G - TAP 0-80 X .150 DP, 10 PLS, MAY DRILL THRU

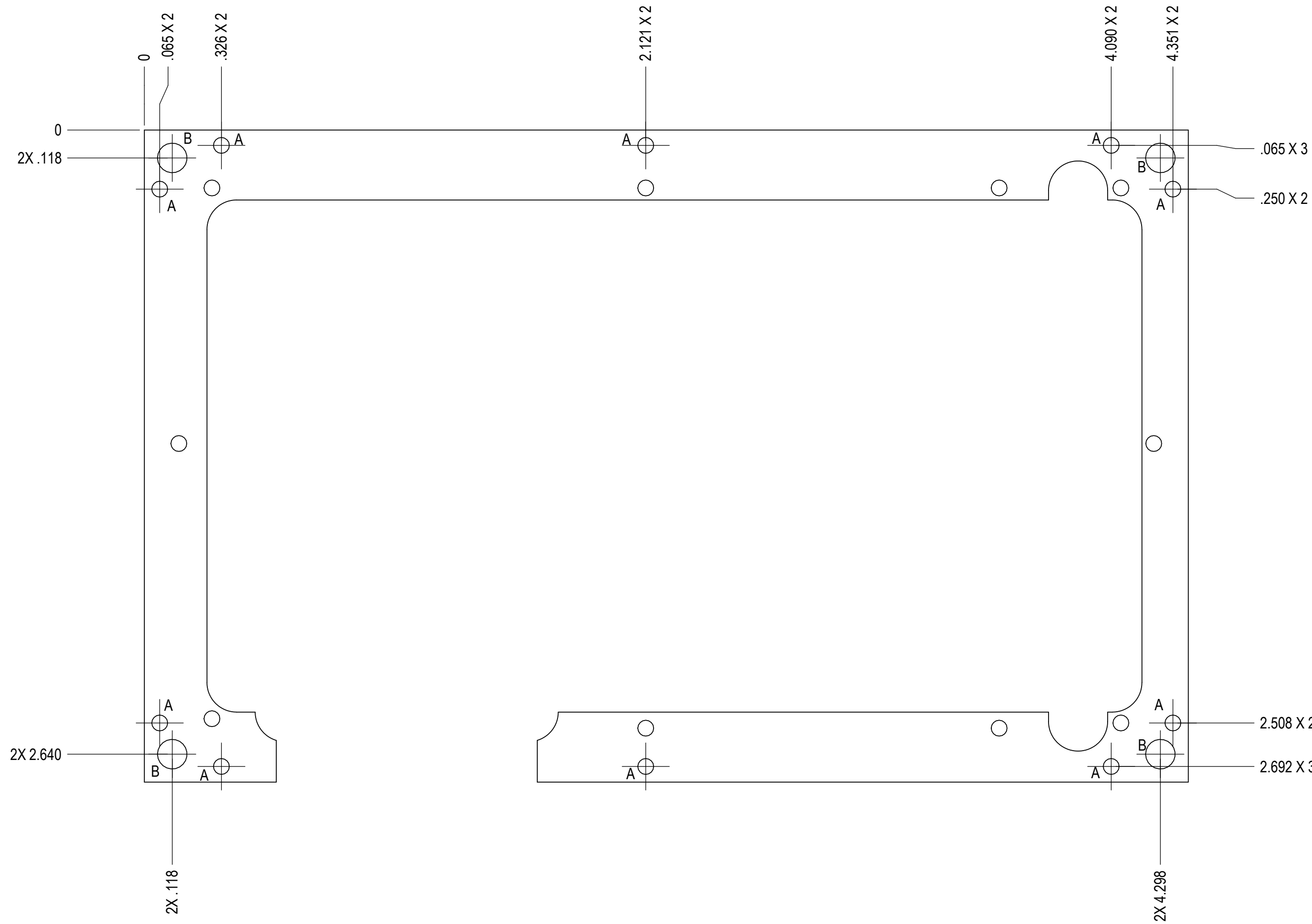

TOP VIEW

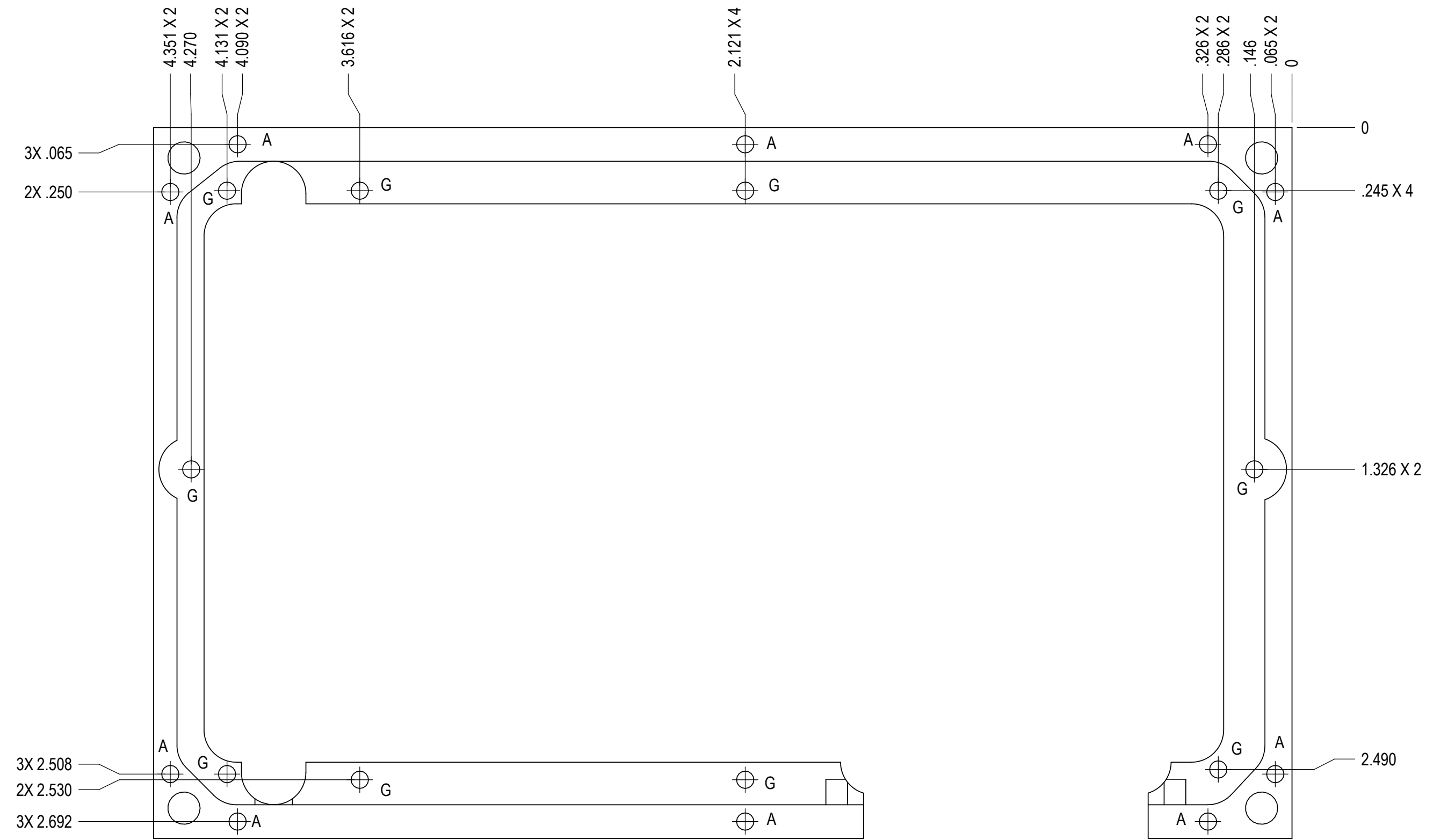

BOTTOM VIEW

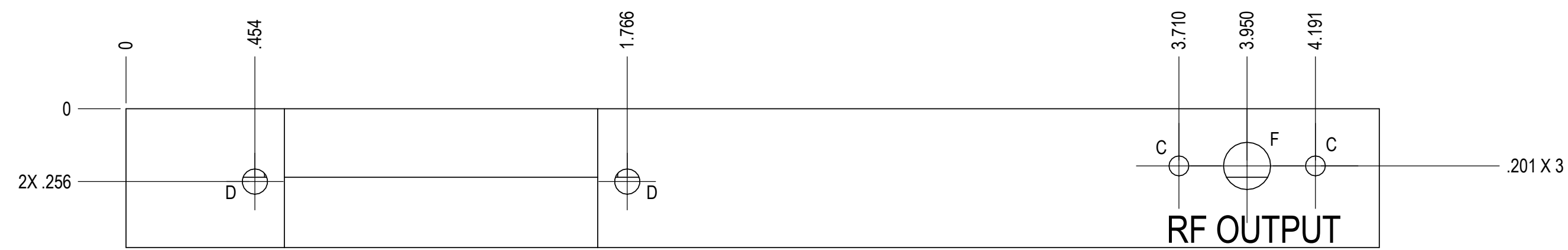

FRONT VIEW

RF OUTPUT

PROPRIETARY AND CONFIDENTIAL
THE INFORMATION CONTAINED IN THIS DRAWING IS THE SOLE PROPERTY OF PRAXIUM, INC. ANY REPRODUCTION IN PART OR AS A WHOLE WITHOUT THE WRITTEN PERMISSION OF PRAXIUM, INC. IS PROHIBITED.

| | | | | | |
|----------------------|---------|--------------------------------------|--------|------|------|
| AL 6061-T6 | | UNLESS OTHERWISE SPECIFIED: | | NAME | DATE |
| TUMBLE | | DIMENSIONS ARE IN INCHES | | | |
| GOLD CHROMATE | | TOLERANCES: | | | |
| | | FRACTIONAL ± | | | |
| | | ANGULAR: MACH ± | BEND ± | | |
| | | TWO PLACE DECIMAL ± | | | |
| | | THREE PLACE DECIMAL ± | | | |
| | | INTERPRET GEOMETRIC TOLERANCING PER: | | | |
| | | MATERIAL: | | | |
| | | | | | |
| NEXT ASSY | USED ON | FINISH | | | |
| APPLICATION | | | | | |

| | | | | | |
|-----------|--|------|--|------|--|
| DRAWN | | NAME | | DATE | |
| CHECKED | | | | | |
| ENG APPR. | | | | | |
| MFG APPR. | | | | | |
| Q.A. | | | | | |
| COMMENTS: | | | | | |

| | | |
|-----------------------------|----------------|--------------|
| TITLE: | | |
| CHASSIS, SYNTHESIZER | | |
| SIZE | DWG. NO. | REV |
| D | 380-010150-001 | - |
| SCALE: 2.5:1 | WEIGHT: | SHEET 2 OF 2 |

D 380-010150-001