

REVISIONS				
ZONE	LTR	DESCRIPTION	DATE	APPROVED
		RELEASE	11-3-05	

DWG NO. 380-010052-001

NOTES

- 1 - ALL RADII .125
- 2 - TEXT FONT MOORPARK
- 3 - ENGRAVE TEXT "RF OUTPUT" AND "GND" .100 HIGH X .015 DP. W/ A 1/32" BALL ENDMILL OR EQUIVALENT CENTERED WITH HOLES AS SHOWN.
- 4 - ENGRAVE TEXT "IF OUTPUT" .100 HIGH X .015 DP. W/ A 1/32" BALL ENDMILL OR EQUIVALENT CENTERED WITH HOLES AS SHOWN.

HOLE LEGEND

- A - TAP 0-80 THRU, 20 PLS (ON THICKER MAT'L, DRILL THRU AND TAP FROM BOTH SIDES 0.230 DP)
- B - DRILL .125 DIA THRU, 4 PLS
- C - TAP 2-56 THRU, 4 PLS
- D - TAP 4-40 THRU, 3 PLS
- F - DRILL .166 DIA THRU, 2 PLS

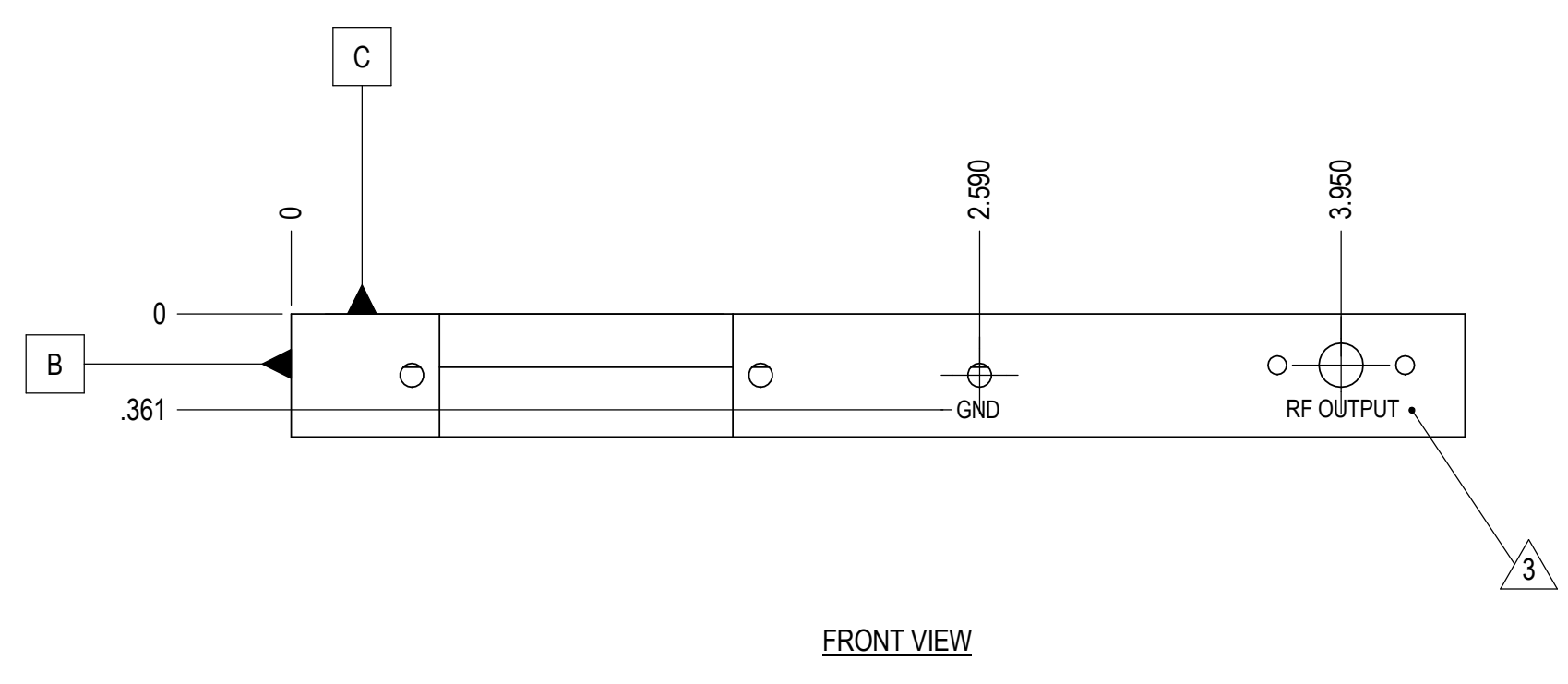
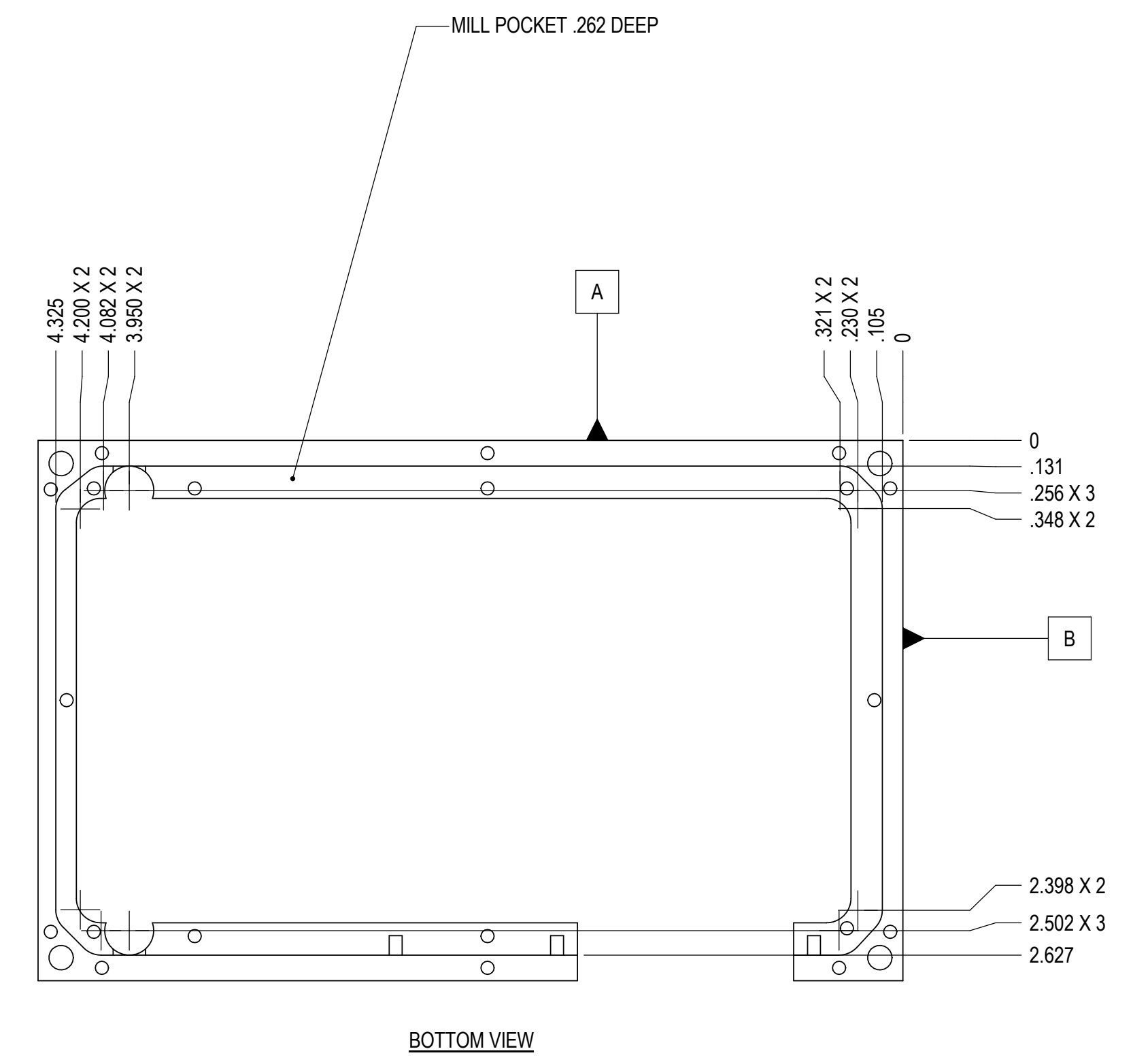
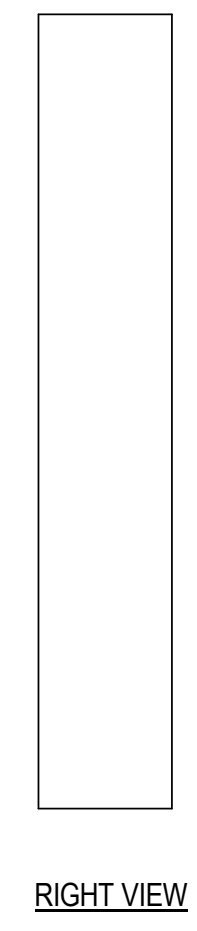
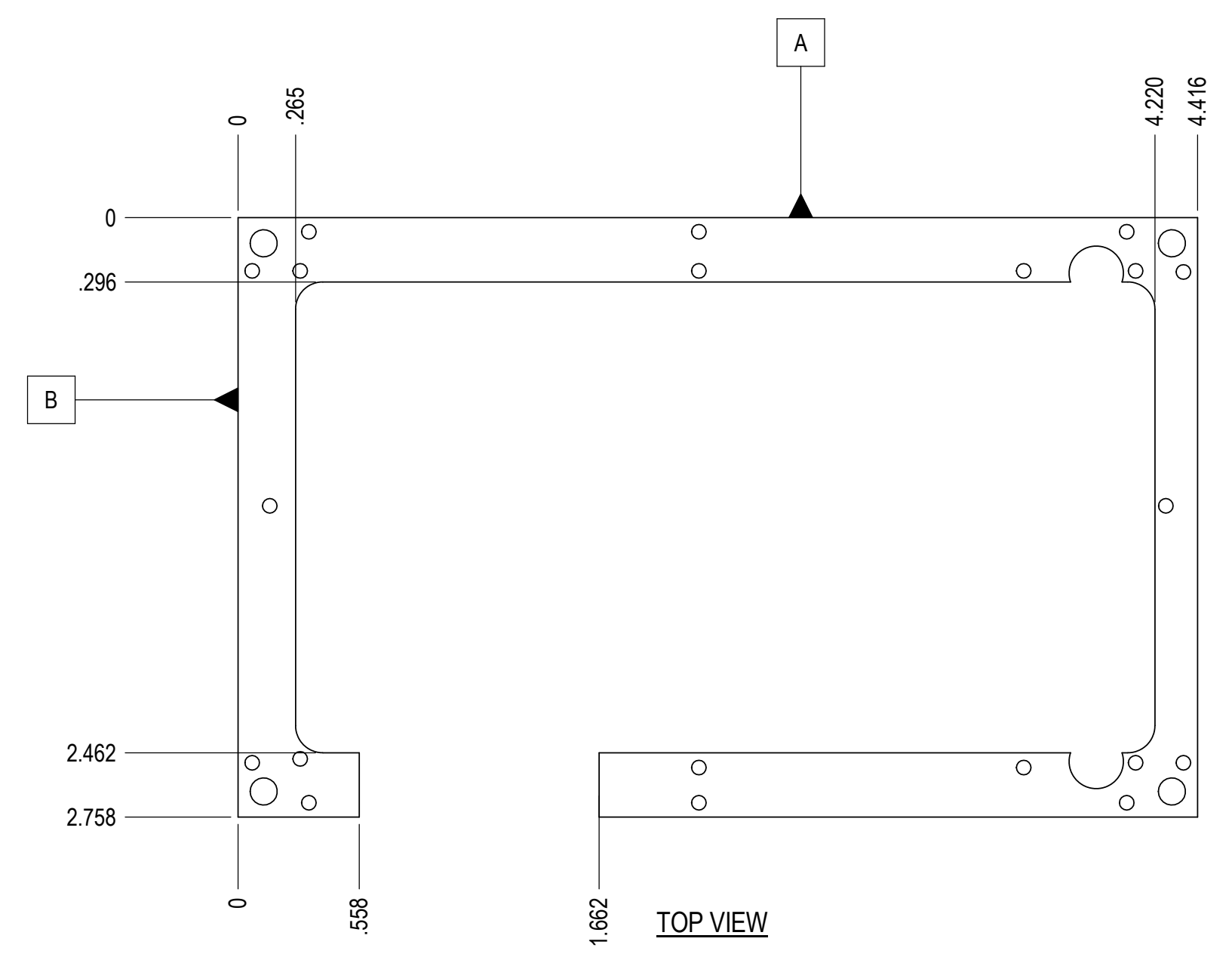
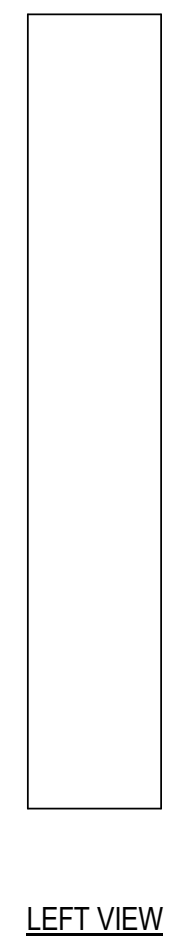
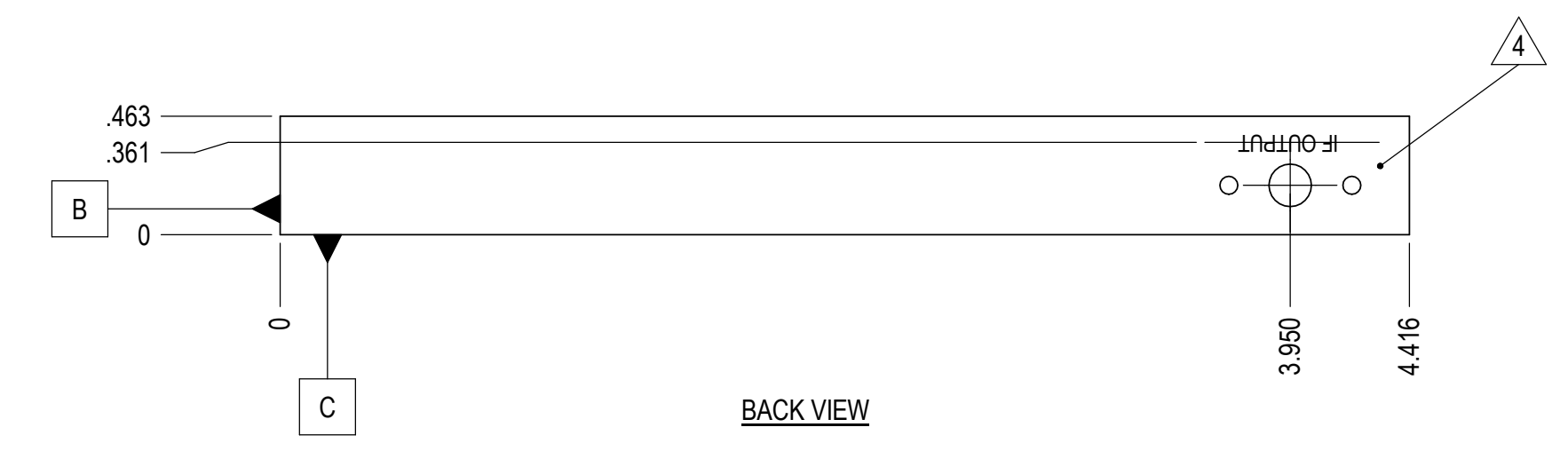

MATERIAL: AL 6061-T6	CONTRACT NO. CONTRACTOR:	120 South Third Street Ft. Worth, TX 76104 (817) 897-1744
FINISH: TUMBLE GOLD CHROMATE	DRAWN BY CHECKED BY Q.C.	ENGINEER PRODUCTION MECHANICAL
NEXT ASSY	USED ON	DESIGN ACTIVITIES APPROVAL
APPLICATION	SCALE 1.5:1	DWG NO. 380-010052-001 REV -
		SHEET 1 OF 2

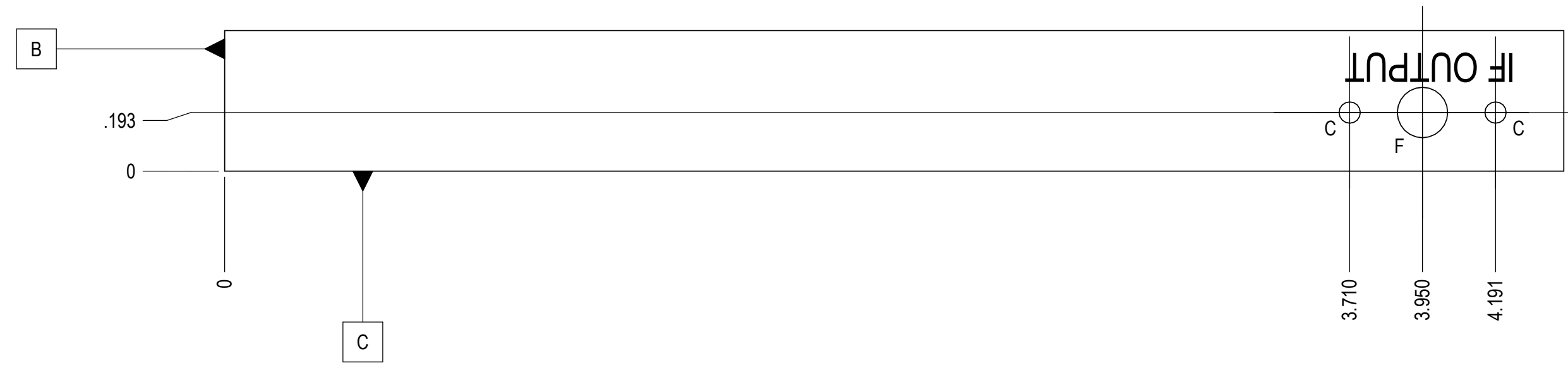

BACK VIEW

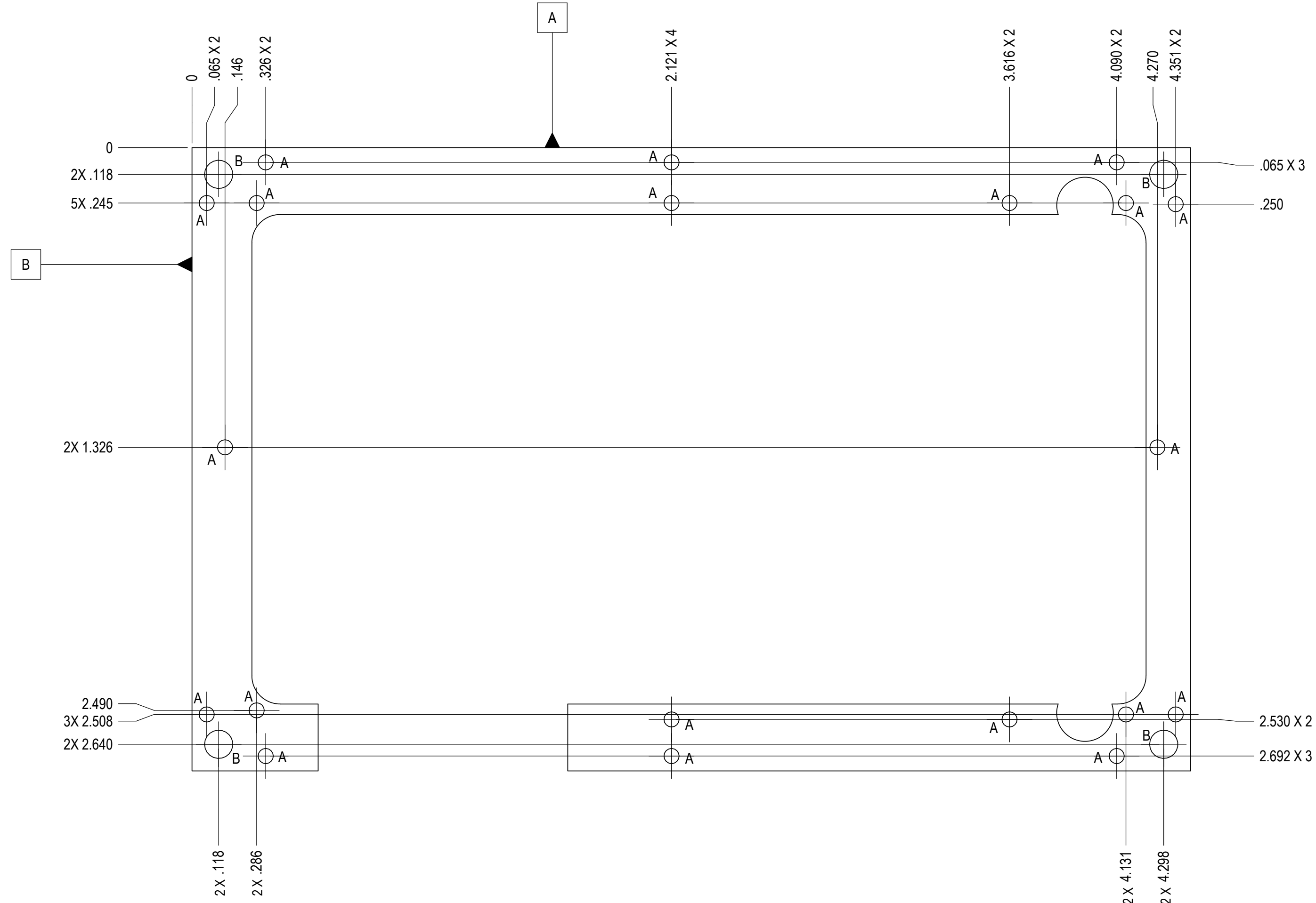

TOP VIEW

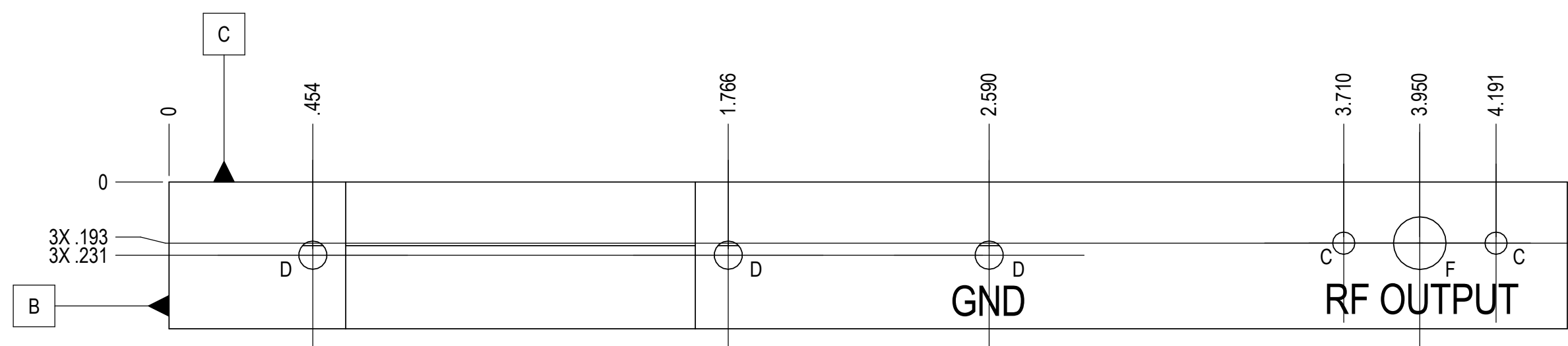

FRONT VIEW

PROPRIETARY AND CONFIDENTIAL
 THE INFORMATION CONTAINED IN THIS
 DRAWING IS THE SOLE PROPERTY OF
 PRAXIUM, INC. ANY REPRODUCTION
 IN PART OR AS A WHOLE WITHOUT THE
 WRITTEN PERMISSION OF PRAXIUM, INC.
 IS PROHIBITED.

		UNLESS OTHERWISE SPECIFIED:		DRAWN	NAME	DATE	TITLE:	
		DIMENSIONS ARE IN INCHES		CHECKED			CHASSIS, SYNTHESIZER	
		TOLERANCES:		ENG APPR:			SIZE DWG. NO. REV	
		FRACTIONAL ±		MFG APPR:			D 380-010052-001 -	
		ANGULAR MATCH ±		Q.A.			SCALE: 2.5:1 WEIGHT: SHEET 2 OF 2	
		BEND ±		COMMENTS:				
		TWO PLACE DECIMAL ±						
		THREE PLACE DECIMAL ±						
		MATERIAL						
		AL 6061-T6						
		FINISH						
		GOLD CHROMATE						
NEXT ASSY		USED ON						
APPLICATION								

D 380-010052-001